

singetex

Singeing line for wovens and open-width knits

Why singeing woven and open-width knitted fabric?

Singeing of woven and knitted fabric takes an important role in fabric pre-treatment, appearance, clean and clear surface before the following process of fabric.

Singeing of woven and knitted fabric is carried out to remove and burn out the hairiness on the fabric surface and produce a smooth surface finish on fabrics.

The process guarantees several purposes like to obtain a clean surface which allows the structure of the fabric to be clearly seen, reduced risk of pilling, better printing of fine designs with an higher clarity and details, less risks of irregular dyeing process especially in dark shades due to diffused reflection of light.

Why singeTEX?

The Cibitex singeing process can guarantee the highest standards of quality in terms of hairiness removal. The uniformity of the flame on the whole width of the burners allows to get the best possible results. The possibility to position the burners in tangential, perpendicular position allows you to run a wide range of articles from the most delicate up to the heaviest one.

The production and controls on the machine are fully automated with the supervision of all the production necessary data for machine setting. The singeing line can be also supplied with a desizing process with the main target to obtain a fabric free from sizes so that the penetration of dyeing, printing and finishing chemicals makes the best possible quality of your products.

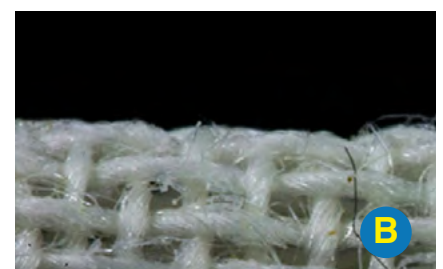

A Before B After

A solution for all your sanforizing requirements

SingeTEX lines are studied, developed and delivered in accordance to the requirements of our customers.

The singeing lines we offer can be completed with various accessories like filters to release clean air in the atmosphere, preparation mixing tanks for the feeding of the desizing unit, filter and heat exchanger for the proper recycling of the desizing bath. The singeing process is used for all those fabrics to which

you can add a value in the final finishing and appearance. The speed of the singeing machine can vary a lot in accordance to type of processed fabric, quality of grey fabric and hairiness.



A. Entrance / B. Brushing unit



C. Double burner singeing unit

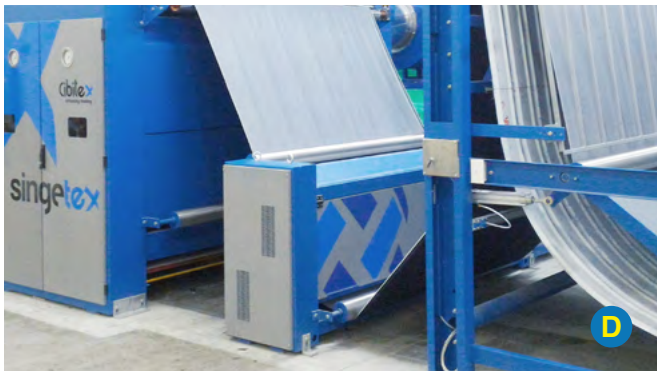

D. Beating unit



E. Desizing Unit



F. Exit

Technical specifications

Working width (mm)

2000 / 2200 / 2400 / 2600

Fabric to be processed

Cotton and blend / Woven or knitted fabrics

Bath for desizing process

Cold or/and hot

Possible use of machine

In accordance to its configuration

Configurations

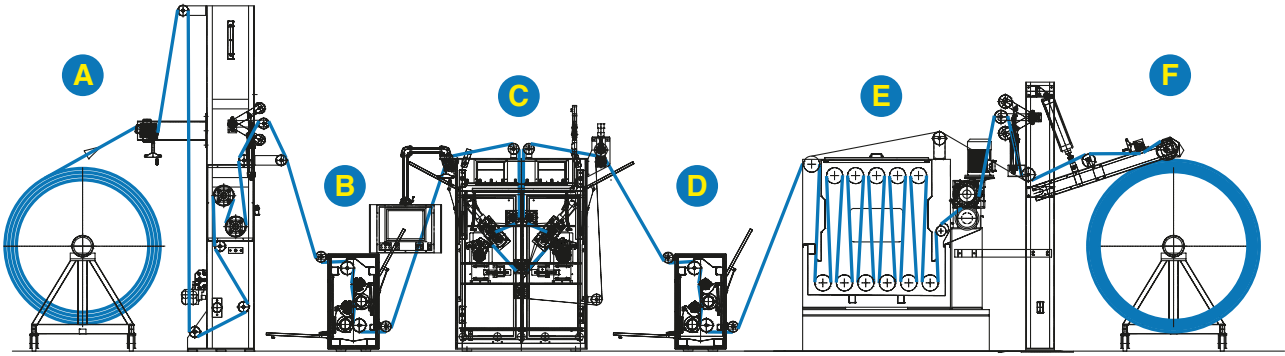

Configuration A

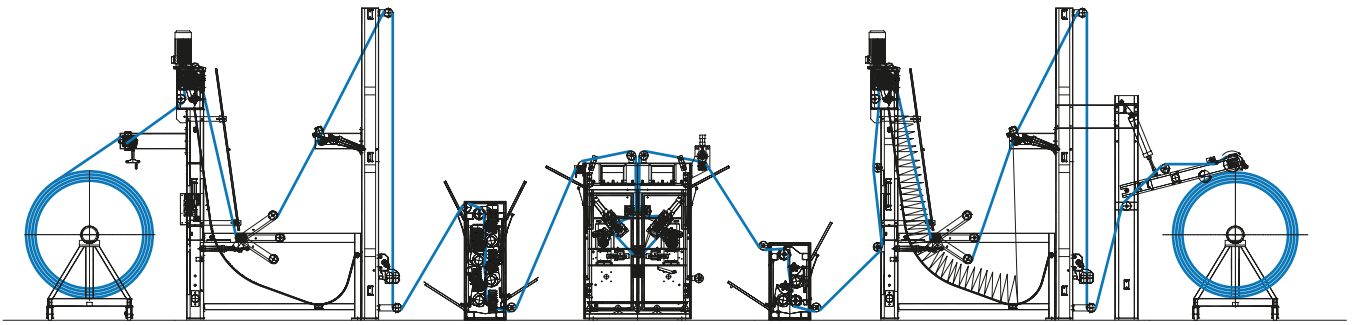

Configuration B

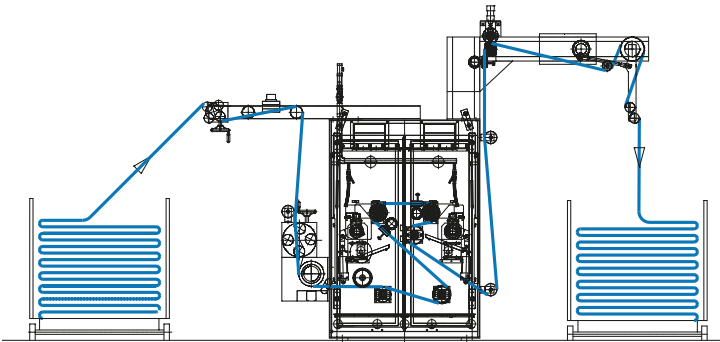

Configuration C

Possible singeing position of burners

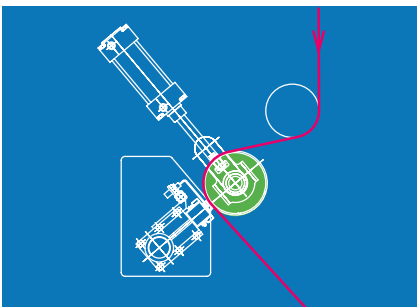

Position 1

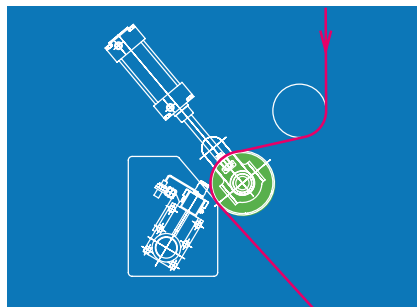

Position 2

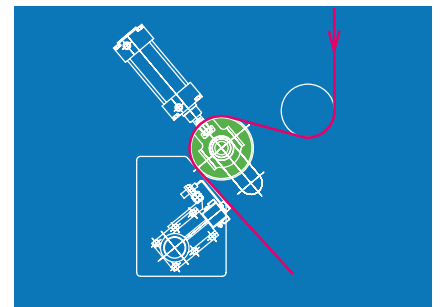

Position 3

We are green

Green philosophy & citizenship

As a proud **member of Acimit** we spend all our efforts to be a sustainable company and provide the textile industry with sustainable technologies. We are based in the heart of the Olona River Valley, in the great Ticino Park area, a Unesco Man & Biosphere Reserve. We take care of our local community and wildlife, reducing the noise and the impact of our manufacturing at the lowest level possible.

- We adopt manufacturing machinery, techniques and behaviours that help **reducing CO₂ emissions and water consumption**.
- We **reduce and recycle** all the waste produced by our manufacturing plant according to the strictest rules.
- We manufacture highly efficient technologies that **reduce power consumption** and allow our customers to respect the environment and save money.

A continuous commitment to be virtuous

Cibitex believes in social responsibility as a core value.

For this reason we're constantly engaged in the adoption of internationally recognized best practices in the conduct of our business and customer, suppliers, partners and stakeholders relationship management.



Service & Maintenance

- **Cibitex customers** do not only buy a product, but can also rely on a partner who's committed to their needs, even the most specific and challenging ones.
- **Cibitex machinery** is equipped with a built-in connection to customer's machinery, which allows our service engineers to detect any malfunctioning and/or schedule possible updates.
- Our service engineers are trained to fix any mechanical, electrical and/or electronic faults.
- **Cibitex** can quickly provide customers with spare parts and services all around the world, thanks to a centralized warehouse and a well established logistic platform.

