

shrinktex

WK series

Sanforizing line for wovens and open-width knits

Why sanforizing woven and open-width knitted fabric?

Sanforizing of woven and knitted fabric takes an important role in fabric properties, appearance, softness and residual fabric shrinkage.

Sanforizing of woven and knitted fabric is carried out for several purposes, and it can vary according to the specific requirement of each customer. This process is needed to avoid that fabrics shrink after their garmenting.

The process guarantees a final dimensional stability near to 0% for wovens which complies with the highest international standards of lab controls while for knits we can go below a final 4-5%. In addition to shrink-proof results, fabrics will acquire softness and a nice finishing surface aspect.

Why shrinkTEX?

The Cibitex sanforizing process can guarantee the highest standards of quality for the control of residual shrinkage in warp and weft direction.

The production and controls on the machine are fully automated with the supervision of all the production necessary data for machine setting. Our lines are the result of a long experience and research in close contact with end users and Cibitex'customers spread all around the world. Such experience is put at disposal of all our new customers who select Cibitex solutions for their finishing and sanforizing process.

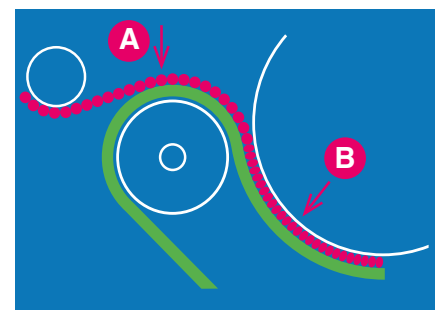

A Prima / Before B Dopo / After

A solution for all your sanforizing requirements

ShrinkTEX lines are studied, developed and up-dated in accordance to fashion's evolution

The sanforizing machines we offer can be completed with various accessories to process a wide range of cotton and blends woven fabrics. The sanforizing process is also used for the processing of synthetics and pigment printed fabrics to assure them a better finishing touch. The sanforizing process is used for all those fabrics having as final destination in particular the garment industry.

The Cibitex finishing process can guarantee the highest standards of quality for the control of residual shrinkage in warp and weft direction and it is the solution adopted by the most resounding world brands in woven sector. The shrinkTEX concept (WK series) allows to achieve speeds of production up to 35-40 mt/min.



A. Entrance



B. Steaming cylinder



C. Shrinkage unit



D. Felt calender



E. Cooling cylinder



F. Exit

Configurations

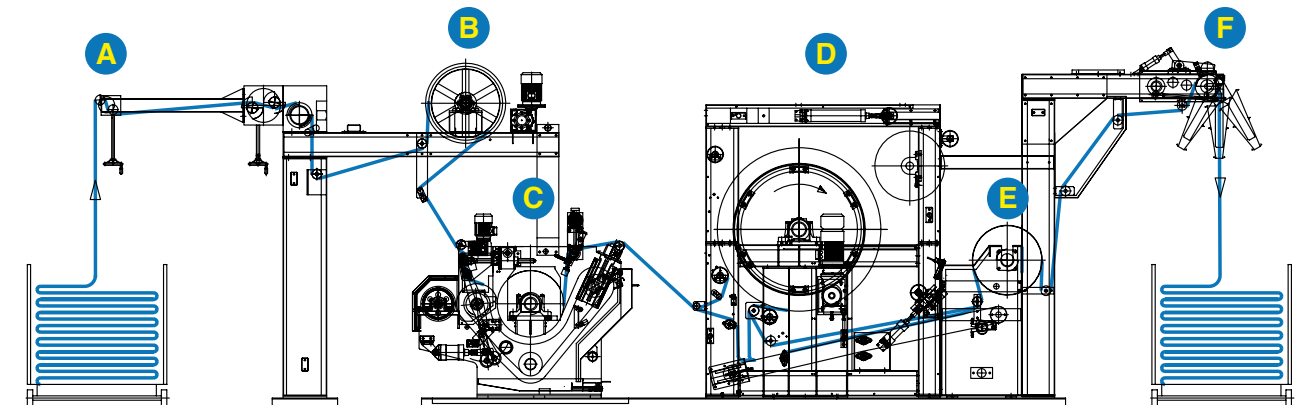

Configuration A

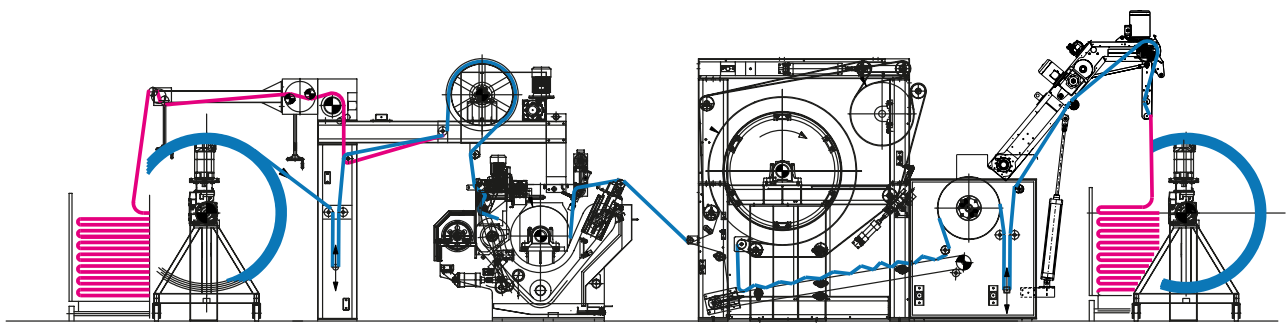

Configuration B

Tailor made

We care about your specific requirements, that's why we use to build every line in accordance to customers needs and we will be pleased to share our knowledge and experience to find the solution for your wovens and knits finishing.

The information collected will enable us to offer you a really tailored solution, to improve the level of your finishing process. A tailor made machine allows you to have the maximum versatility and gives you the possibility to improve your investment and costs of production.

Cibitex is at your complete disposal to share its know-how.

Water recycling

Thanks to our care for the environment and efforts to reduce pollution, it's possible to complete Cibitex finishing lines with solutions to save the water used during the process and recycle it, with many advantages in costs savings in production. Different solutions can be provided.

Technical specifications

Working width (mm)

1800 / 2000 / 2200 / 2400 / 2600

Felt calender diameter (mm)

1500

Fabric to be processed

Cotton and blend wovens
Woven or knitted fabrics

Possible use of machine

In accordance to its configuration

We are green

Green philosophy & citizenship

As a proud **member of Acimit** we spend all our efforts to be a sustainable company and provide the textile industry with sustainable technologies. We are based in the heart of the Olona River Valley, in the great Ticino Park area, a Unesco Man & Biosphere Reserve. We take care of our local community and wildlife, reducing the noise and the impact of our manufacturing at the lowest level possible.

- We adopt manufacturing machinery, techniques and behaviours that help **reducing CO₂ emissions and water consumption**.
- We **reduce and recycle** all the waste produced by our manufacturing plant according to the strictest rules.
- We manufacture highly efficient technologies that **reduce power consumption** and allow our customers to respect the environment and save money.

A continuous commitment to be virtuous

Cibitex believes in social responsibility as a core value. For this reason we're constantly engaged in the adoption of internationally recognized best practices in the conduct of our business and customer, suppliers, partners and stakeholders relationship management.



Service & Maintenance

- **Cibitex customers** do not only buy a product, but can also rely on a partner who's committed to their needs, even the most specific and challenging ones.
- **Cibitex machinery** is equipped with a built-in connection to customer's machinery, which allows our service engineers to detect any malfunctioning and/or schedule possible updates.
- Our service engineers are trained to fix any mechanical, electrical and/or electronic faults.
- **Cibitex** can quickly provide customers with spare parts and services all around the world, thanks to a centralized warehouse and a well established logistic platform.

