

# CENTERING/SPREADING/ FABRIC GUIDES DOGAL



**Bianco® Fabric Guides** include several types of machine used for spreading and centering fabric in various finishing processes.

**Bianco® Fabric Guides** family includes:

- Bianco® Compact CE
- Bianco® KB10
- Bianco® Dogal 01
- Bianco® Dogal 02
- Bianco® Dogal 03
- Bianco® Dogal 04
- Bianco® Dogal 05



## DOGAL 01



## DOGAL 02



## DOGAL 04

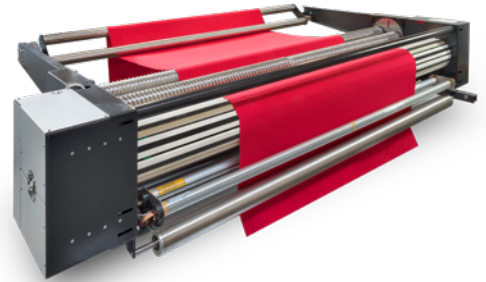

## DOGAL 05

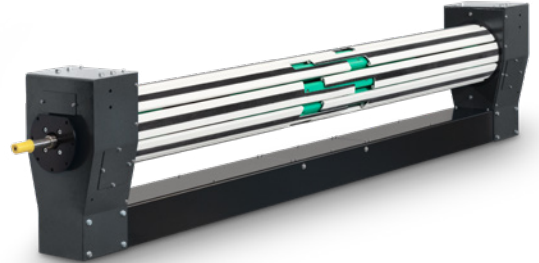

### overall dimensions L x H x W

Dogal 01 515x520mm (RW+764mm) - weight 280kg  
Dogal 02 diam120/150mm (RW+400mm) - weight 48kg  
Dogal 04 860x520mm (RW+764mm) - weight 330kg  
Dogal 04 with entry brake weight 1720x520mm (RW+764mm) - weight 500kg

### material

carbon steel or stainless steel

### color on painted steel

RAL 7021 for the structure RAL 9006 for side doors

### rollers width

from 1600 mm to 4200 mm (up to 5000 on request, with special actuator)

### fabric width

from 1400 mm to 4000 mm

### min working width

400 mm

### max working width

RW-200 mm

### mechanical speed max

150 m/min

### max compressed air

6 bar

### voltage

standard 3x400VAC-50Hz or others on request

### standard auxiliary circuit

24VDC

### installed power

2 kW

### motorization

AC controlled by inverter

### ambient temperature

from 0° to +55°

### noise

<75 dB(A)

### actuator type

pneumatic or electropneumatic

### fabric position control

alignment by means of ON/OFF photocell, bianco FTC5 proportional photocell, or by means of the bianco FLUO optical reader

### surface material of slats

Dogal 02: stainless steel

Dogal 01/03/04: stainless steel, rubber, silicone rubber, rubber grip (MOHAIR)

### electrical cabinet

independent or built into the system



www.bianco-spa.com

# CENTERING/SPREADING/ FABRIC GUIDES DOGAL

**Bianco® Fabric Guides** include several types of machine used for spreading and centring fabric in various finishing processes.

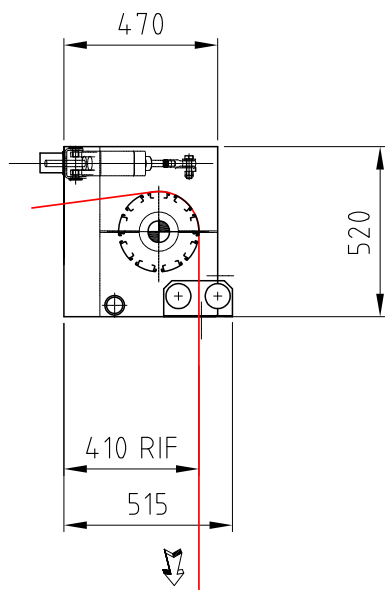

## Bianco® DOGAL 01

**Bianco® DOGAL 01** is a compact slatted system that centres the fabric during processing. The position of the fabric is detected by a Bianco® FLUO full height sensor or edge-guide photocells. The pneumatic or motorized slatted cylinder moves the fabric into the required position by the movement of its slats combined with the rotation of the roller.

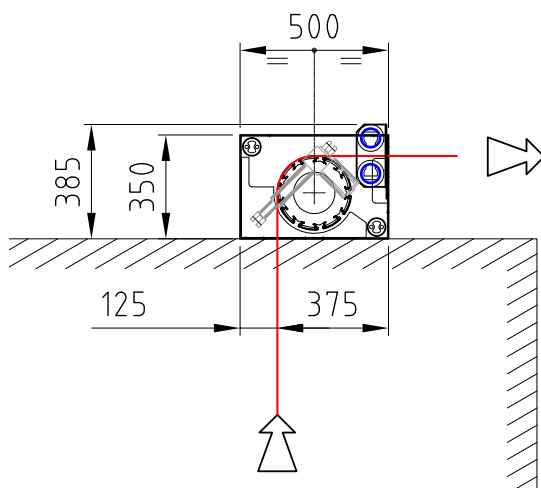

## Bianco® DOGAL 03

**Bianco® DOGAL 03** is a slatted system for fabric centring and distension that combines the features of DOGAL 01 with those of DOGAL 02 and is normally used to obtain the high precision results required in printing lines.

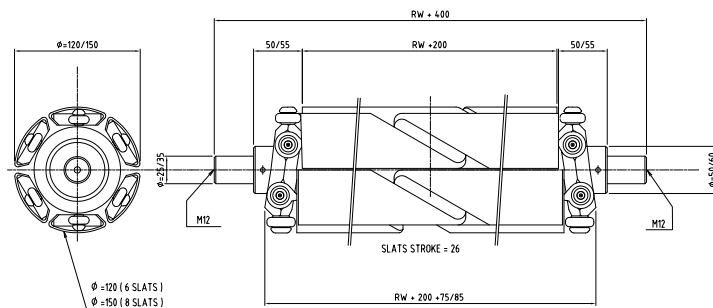

## Bianco® DOGAL 02

**Bianco® DOGAL 02** is a slatted cylinder for fabric spreading, available in various diameters.

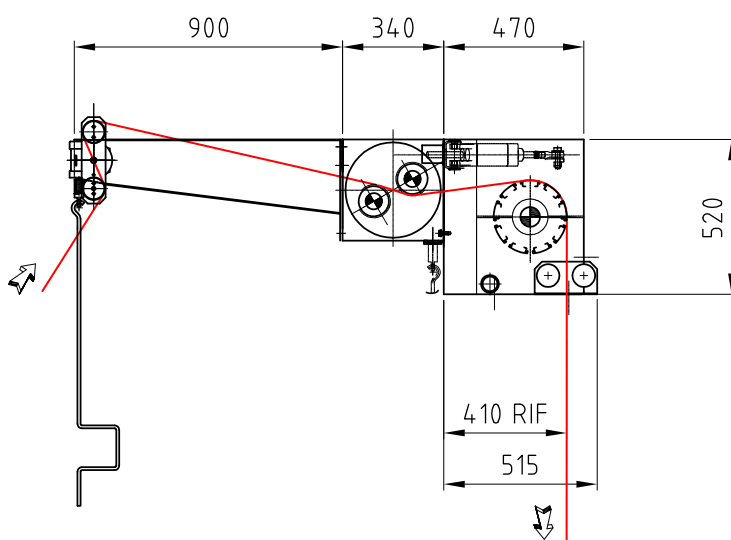

## Bianco® DOGAL 04

With the addition of the 360° spreading unit you get the **Bianco® DOGAL 04**, with optional input frame with tensioning brake in various solutions. The 360° spreading unit facilitates distension of the fabric thanks to two spiralled scroll rollers (different profiles available) which rotate in the opposite direction to the advancement of the fabric. The drawing-in angle of incidence of the two rollers can be adjusted.

## Bianco® DOGAL 05

**Bianco® DOGAL 05** is a fabric centring and stretching unit, made of a roller whose surface is composed of a crown of slats with a diameter of 216 mm, formed by two segments of a special AISI 304 steel profile, and partially superimposed in the central section of the roller. The ends of these latter are connected to an oscillating ring on each side, the oscillation causes the slats to move transversely to the direction of travel of the fabric and this, dragged by the rotation of the drum, reaches the desired position.