

GREIGE FABRIC SLITTING

Bianco® Slitting lines for greige fabric to cut the tubular fabric before finishing.

Bianco® greige fabric slitting includes:

- Bianco® Simple slitter on fold
- Bianco® Reverse slitter
- Bianco® Slitter with triangle



SIMPLE

The Bianco® Simple slitter on fold allows cutting and opening of the greige tubular fabric knitted on circular looms. The cutting will take place on the fold of the fabric by disc blade, which is longitudinally adjustable according to the different fabric widths. Lever plaiter mounted at the line exit.

REVERSE

The Bianco® Reverse slitter is ideal for rope tubular fabric from rope coming from trolley or from small rolls, both for wet and dry fabrics. The reverse basket allows a reduction of the overall dimensions of the machine and consequently of the tension exerted on the fabric. Lever plaiter mounted at the line exit.

WITH TRIANGLE

The Bianco® Slitter with triangle for rope opening and cutting of tubular knitted fabric, developed for continuous and high-speed automatic operation. Lever plaiter mounted at the line exit.

overall dimensions LxHxW	Slitter on fold 3700x 2800x (RW+600) weight 1400Kg Reverse Slitter 3400x 3925x (RW+1160) weight 2000Kg Slitter with Triangle 5800x 5500x (RW+1120) weight 2800Kg
material	carbon steel or stainless steel
color on painted steel	RAL 7021 for the structure RAL 9006 for side doors
turntable diameter	1700 mm (on request 2000mm)
rollers width	from 2000 mm to 3000 mm
fabric width	from 1800 mm to 2800 mm
max tubular dimension	Ø 800 mm (on request Ø 900 or Ø 1000mm)
sensor type	bianco TGLSK3 vision system, linear sensor CMOS 1024 points, resolution 68 micron
max mechanical speed	120 m/min
max compressed air	6 bar
standard voltage	standard 3x400 Vac – 50 Hz or others on request
installed power	Slitter on fold 4 Kw Reverse Slitter 5 Kw Slitter with Triangle 10 Kw
motorization	A/C controlled by inverter
ambient temperature	from 0° to + 55 ° (optional A/C for electrical cabinet)
noise	<75 dB(A)
operator pannel	Schneider touch-screen
control PLC	Schneider
teleservice	optional



www.bianco-spa.com

GREIGE FABRIC SLITTING

Bianco® slitting lines for greige fabric to cut the tubular fabric before finishing.

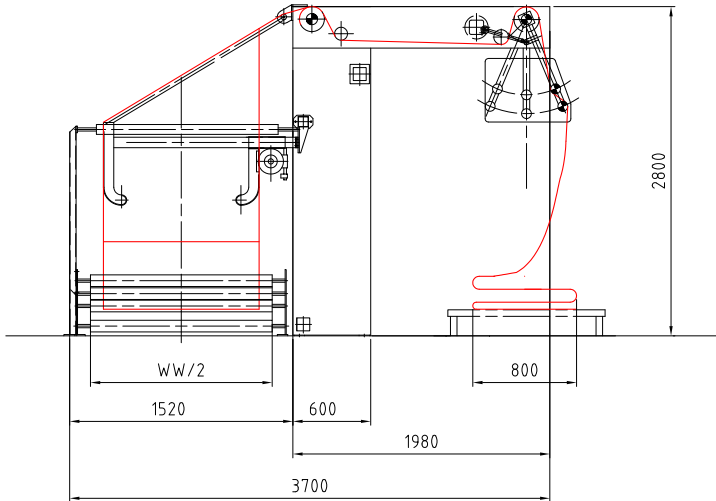

The Bianco® Simple Slitter on fold

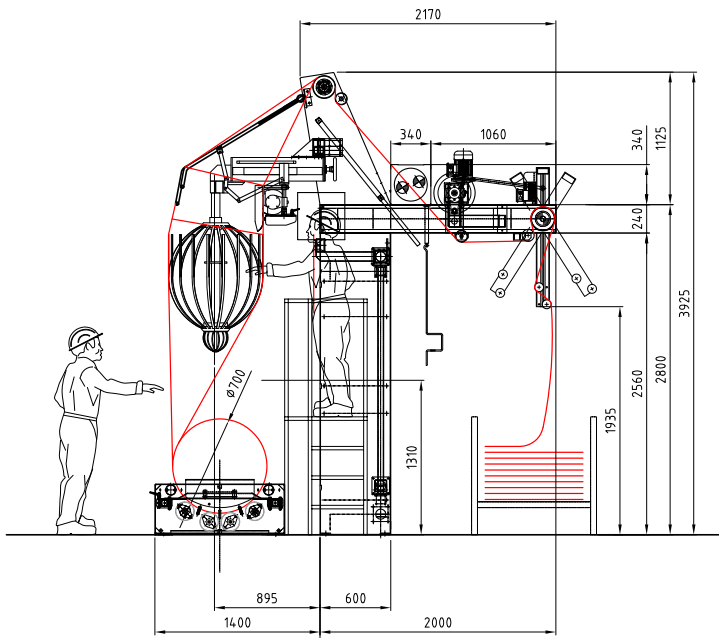

Bianco® Reverse Slitter

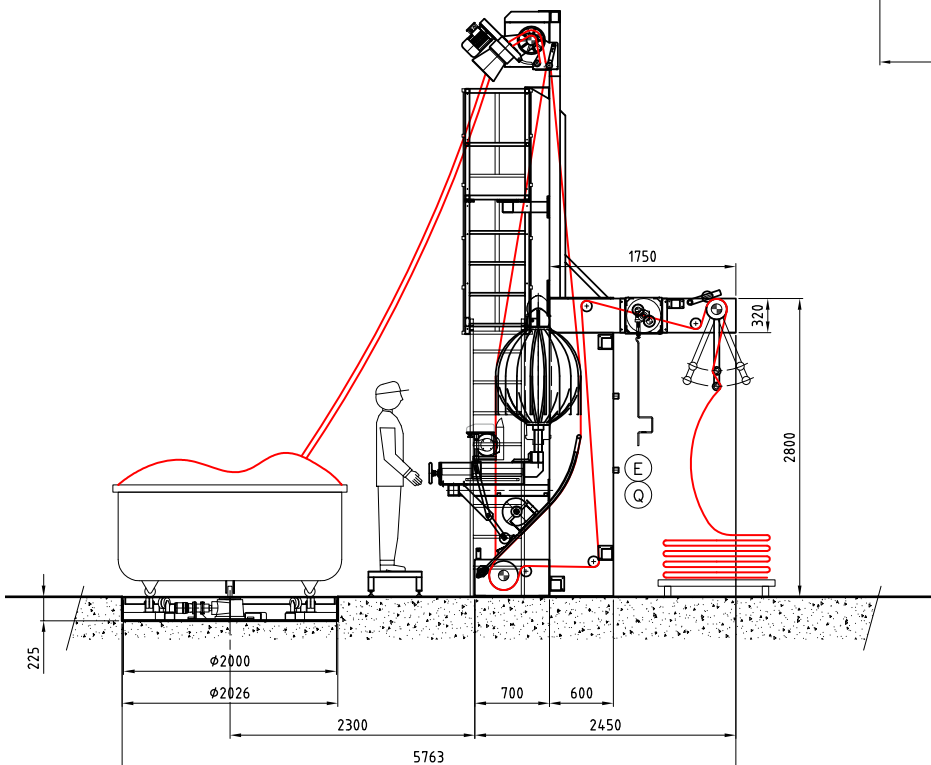

Bianco® Slitter with Triangle