

Wanny 4 (2+2)

YARN DYED SCOURING

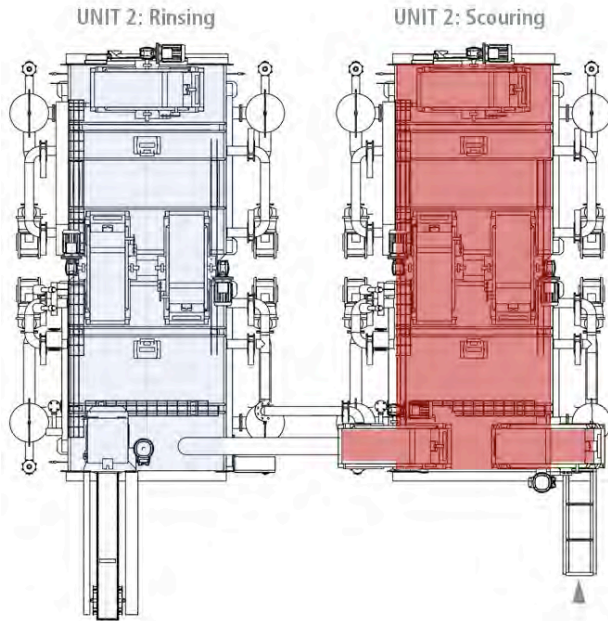

Chemicals: detergent, sequestering agent, caustic soda, acetic acid
Average productivity: 500 kg/h

ANTIPELLING ENZYMING

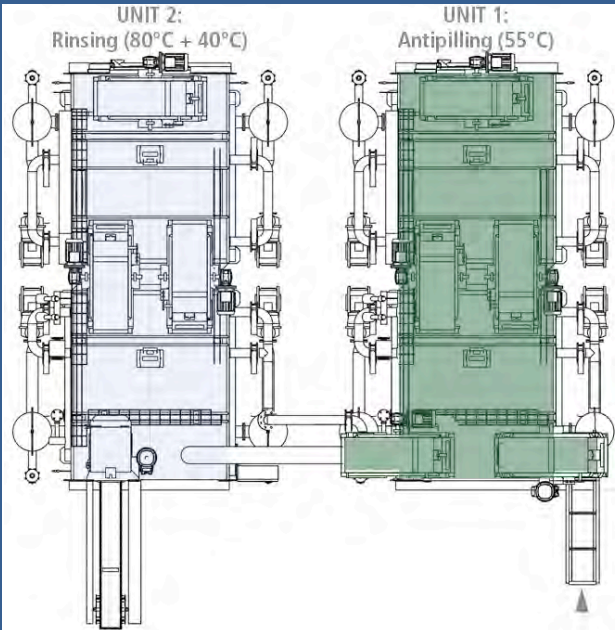

Chemicals: enzymes, acetic acid
Average productivity: 400 kg/h

PRE-BLEACH

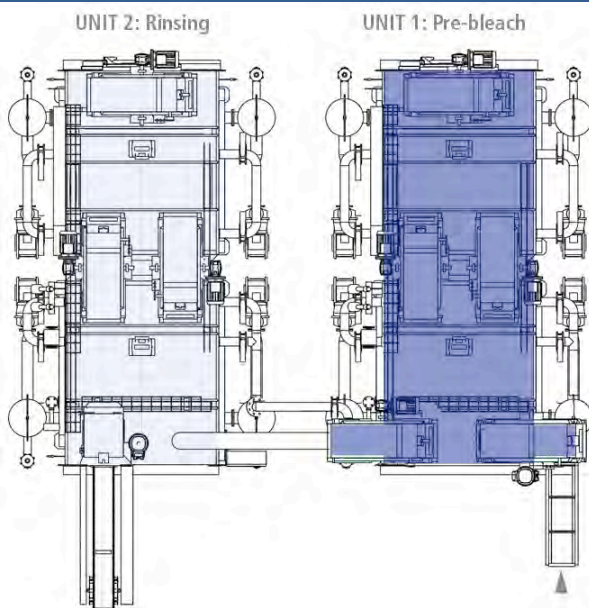

Chemicals: caustic soda, peroxide, detergent, stabilizer, sequestering agent, acetic acid
Average productivity: 400 kg/h

OPTICAL WHITE

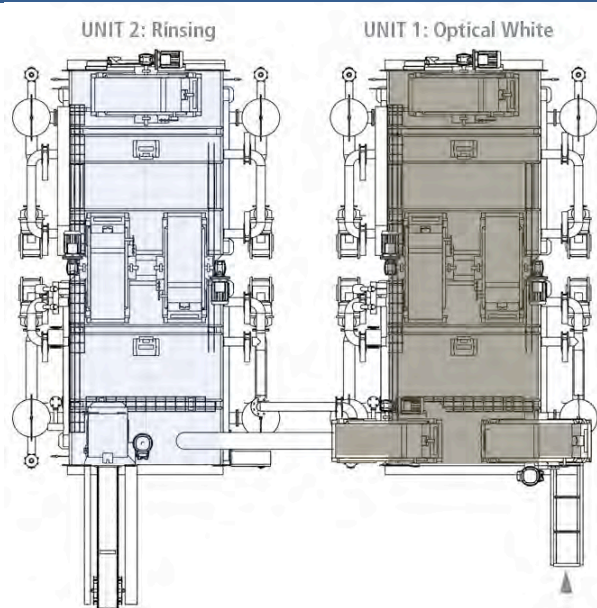

Chemicals: caustic soda, peroxide, detergent, stabilizer, sequestering agent, acetic, optical white
Average productivity: 400 kg/h